



# COVAL

vacuum managers

FlowPack Suction Cups

## FPC series





# FPC Series: Universal

## A Collection of Innovations

The shape of the lip has been designed to match the deformation of flexible packaging and ensure the best possible seal during positioning; which, as an additional advantage, allows for a reduction in power of the vacuum generator. The FPC suction cups are also equipped with cleats that stiffen the lip and reinforce the clamping effect.

- ❶ **Thin and wavy flower-shaped lips** that perfectly mold to the packaging, whatever the shape.
- ❷ **Internal cleats** that allow for optimized vacuum while preventing any crushing and also strengthen the hold on the product being handled.
- ❸ **Fittings featuring a lateral vacuum distributor** that prevent any loss in efficiency when the product is held.
- ❹ **Materials: Food-grade** silicone and plastic insert meets FDA and CE standards.



*Focusing on the needs of its customers in the food industry, COVAL, a company certified ISO 9001: V2015, has developed a series of particularly innovative silicone cups, dedicated to the high-speed handling of flexible packaging.*

*Combining great flexibility and food compatibility, the new FPC Series suction cups have been specially designed to optimize the handling of packed bags from 100 g to 5 kg. E.g. - FlowPack, DoyPack, etc.*

## Advantages

### WITHSTANDS HIGH PRODUCTION RATES:

- Its gripping ability allows for high production rates.
- No interruption in the packaging line due to faulty gripping.

### SAFETY:

- The FPC Series suction cup is made of silicone, a material that is recommended for its temperature resistance and food safety. The plastic fittings also conform to food standards.

### ENERGY SAVINGS:

- The airtightness of FPC Series suction cups avoids the need for an oversized vacuum generator, allowing for considerable energy savings.

### SUITABLE FOR ALL FLOWPACKS:

- Different forms and dimensions for a suitable solution.

## A Complete Range

### AVAILABLE IN TWO SIZES:

- Round, Ø 60 mm.
- Elliptical, 120 x 100 mm.

### TWO LEVELS OF FLEXIBILITY:

- 35 and 50 Shore.

### MATERIALS:





FPC suction cups are compatible with FDA food standards (FDA 21 CFR 177.2600.) and meet the European regulation (EC) 1935/2004.

- **Suction cups:** Silicone.
- **Fittings:** Plastic POM-C and PETP.
- **Flat Seal:** Silicone.
- **Screw:** Stainless Steel.



# FlowPack Suction Cups

## Characteristics

	Dim. (mm)	 (cm <sup>3</sup> )	 (N) <sup>(1)</sup>	Shore Hardness	 (g)	ØA (mm)	L (mm)	I (mm)	f <sup>(2)</sup> (mm)	H (mm)	H1 (mm)	ØG (mm)	E  (mm)
FPC60SIBL3IF38PC	Ø 60	24.5	15	35	21.5	Ø 60	/	/	10	26	33	G3/8"-F	26
FPC60SIBL5IF38PC	Ø 60	24.5	15	50	21.5	Ø 60	/	/	10	26	33	G3/8"-F	26
FPC120100SIBL3IF38P1V	120x100	167	50	35	92.1	/	/	100	15	32.5	42.5	G3/8"-F	/
FPC120100SIBL5IF38P1V	120x100	167	50	50	92.1	/	120	100	15	32.5	42.5	G3/8"-F	/

(1) Actual force of the suction cup in use with 65% vacuum and including a safety factor of 2.

(2) f = deflection of the suction cup.

## Dimensions "Suction Cup + Fitting"

**FPC120100** Elliptical, 120 x 100 mm

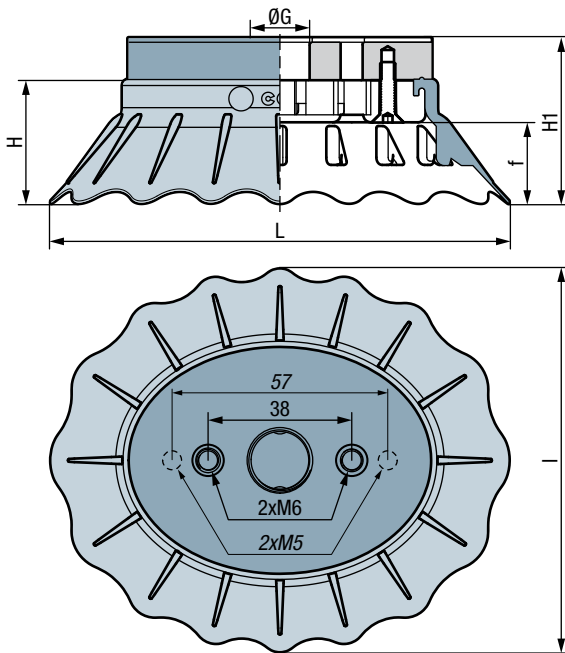

**FPC60** Round, Ø 60 mm

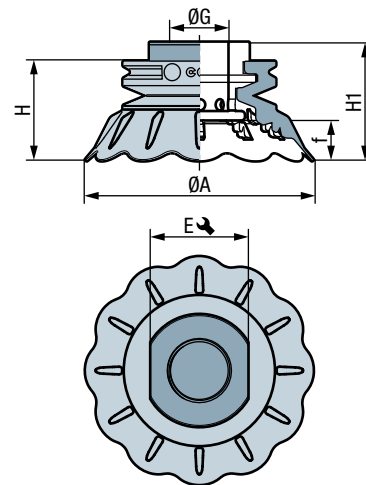

## Mounting Configurations

### FPC60

- Via G3/8"-F connection

### FPC120100

- From below: 2 M5x20 screws(not included)

- From above: 2 M6x16 screws(not included)



To Order:

## FPC60 Round, Ø 60 mm

### COMPLETE PART CONFIGURATION

SUCTION CUP  
+  
G3/8"-F FITTING:

▪ Hardness 35 Shore  
**FPC60SIBL3IF38PC**

▪ Hardness 50 Shore  
**FPC60SIBL5IF38PC**



### INDIVIDUAL PART REFERENCE

G3/8"-F FITTING ONLY:  
**IF38PFPC60**

### SUCTION CUP ONLY:

▪ Hardness 35 Shore  
**FPC60SIBL3**

▪ Hardness 50 Shore  
**FPC60SIBL5**

## FPC120100 Elliptical, 120 x 100 mm

### COMPLETE PART CONFIGURATION

SUCTION CUP  
+  
LOWER PLATE  
+  
UPPER PLATE G3/8"-F  
+  
FLAT SEAL:

▪ Hardness 35 Shore  
**FPC120100SIBL3IF38P1V**

▪ Hardness 50 Shore  
**FPC120100SIBL5IF38P1V**

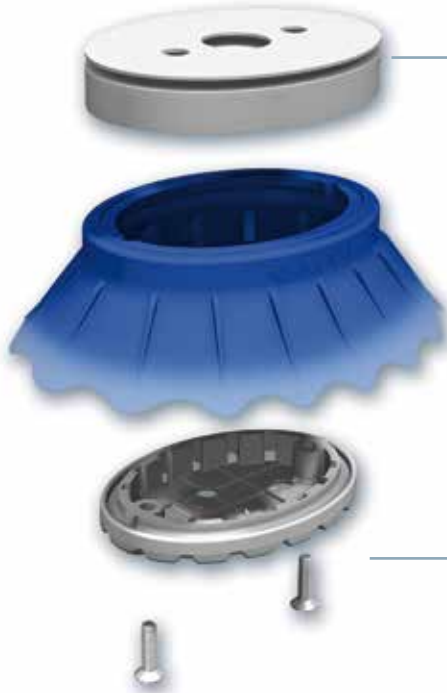

### INDIVIDUAL PART REFERENCE

UPPER PLATE G3/8"-F + FLAT SEAL:  
**IF38PFPC120**

### SUCTION CUP ONLY:

▪ Hardness 35 Shore  
**FPC120100SIBL3**

▪ Hardness 50 Shore  
**FPC120100SIBL5**

LOWER PLATE + 2 STAINLESS SCREWS M4x16:  
**IL1PFPC120**



**3D**  
**COVAL Data**

On our site [www.coval.com](http://www.coval.com) you will find 3D models of all our products, in formats suitable for the principal CAD software.

### FPC VIDEO

Discover the FPC suction cups in action!

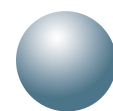

# FlowPack Suction Cups



## Applications

The FPC series suction cups are dedicated to the handling of flexible packaging such as FlowPack, Doypack, etc.

FlowPack < 1.5kg: suction cup Ø 60 mm, FPC60.

FlowPack ≤ 5 kg: oval suction cup 120x100 mm, FPC120100.



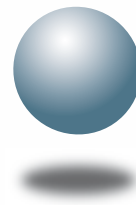

**COVAL**  
vacuum managers

## vacuum components



### A TECHNOLOGICAL PARTNER ON A GLOBAL SCALE

Located in the southeast region of France, COVAL conceives, manufactures and globally distributes high performance, advanced vacuum automation components and systems for industrial applications in all branches.

COVAL is an ISO 9001: V2015 certified company which offers innovative solutions integrating reliable and optimized components with intelligent functionalities. The focus is to provide the most personalized and economic solution to a given application while assuring a significant improvement in the productivity and the safety for the vacuum users around the world.

COVAL has an ambition for technical excellence and innovation. As a specialist in vacuum automation, COVAL is reputed for offering reliable, personalized, cost effective and productive solutions.

The references of COVAL can be found in several industrial sectors (Packaging, Automotive Industry, Plastic, Graphic, Aeronautic...) where vacuum handling is important for high efficiency and productivity.

COVAL markets its products and services all over Europe, in the United States and South America through its subsidiaries and authorized distribution network. COVAL strives to provide customer driven solutions and gives the best possible treatment to satisfy all its clients.

*For all enquiries from Australia, Africa and Asia kindly contact COVAL head office in France.*

Distributed by:



COVAL S.A.S.  
Head Office  
ZA des Petits Champs  
26120 Montélier France  
Tel : +33 (0)4 75 59 91 91  
Fax : +33 (0)4 75 59 91 05

[www.coval.com](http://www.coval.com)